



### Type B New drainage strainer

Dallai is pleased to introduce the new drainage pillars strainer. "Pillars" design permits a larger water flow, compact dimensions make it easy to use, welded steel rods give durability and strenght over time. From your experience in the field to our continuous research for innovative products to simplify and increase efficiency in critical applications, comes the development of this product in 4", 6" and 8" Type B with Galvanized Female.

#### Art. 0941C

	Ø	A x B mm	n° of slot
0941C108S00B	4"	29 X 140	12
0941C159S00B	6"	46 X 240	12
0941C194S00B	8"	59 X 240	12

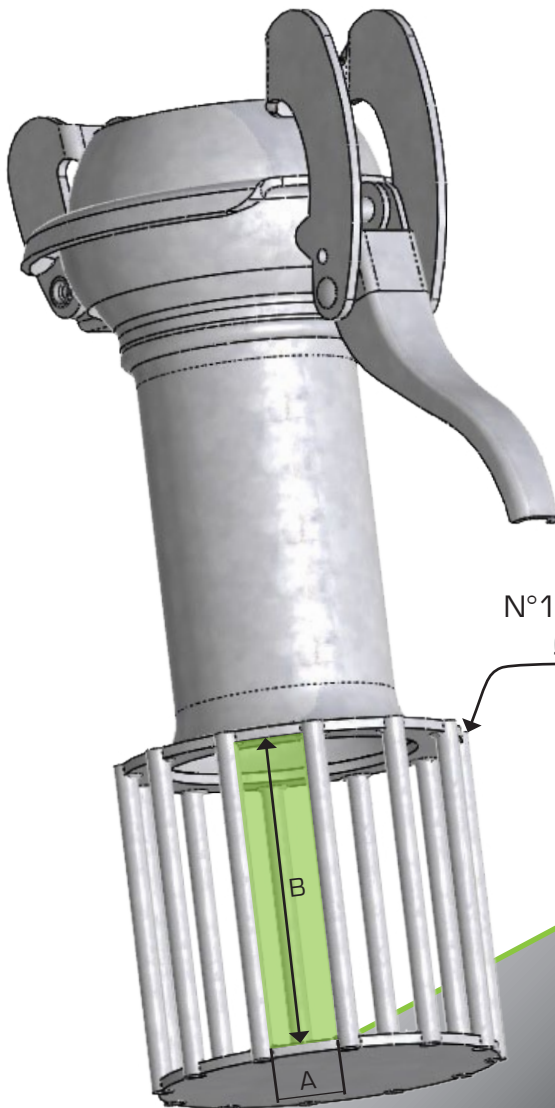

N°12 Pillars  
Ø10mm

